

SOT-323 Plastic-Encapsulate Transistors

FEATURES

- Complementary to S9013W
- Excellent h_{FE} linearity

MARKING: 2T1

MAXIMUM RATINGS ($T_a=25^\circ\text{C}$ unless otherwise noted)

| Symbol | Parameter | Value | Unit |
|-----------------|--|----------|--------------------|
| V_{CBO} | Collector-Base Voltage | -40 | V |
| V_{CEO} | Collector-Emitter Voltage | -25 | V |
| V_{EBO} | Emitter-Base Voltage | -5 | V |
| I_C | Collector Current | -500 | mA |
| P_C | Collector Power Dissipation | 200 | mW |
| $R_{\theta JA}$ | Thermal Resistance From Junction To Ambient | 625 | $^\circ\text{C/W}$ |
| T_J, T_{stg} | Operation Junction and Storage Temperature Range | -55~+150 | $^\circ\text{C}$ |

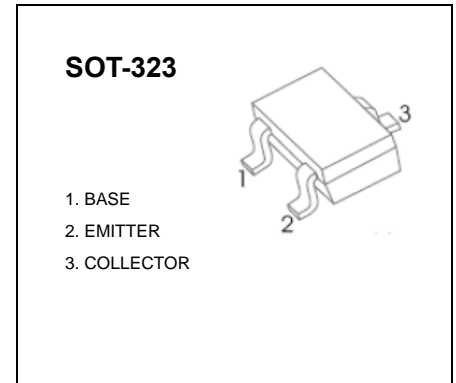

ELECTRICAL CHARACTERISTICS ($T_a=25^\circ\text{C}$ unless otherwise specified)

| Parameter | Symbol | Test conditions | Min | Typ | Max | Unit |
|--------------------------------------|---------------|---|-----|-----|------|---------------|
| Collector-base breakdown voltage | $V_{(BR)CBO}$ | $I_C = -100\mu\text{A}, I_E = 0$ | -40 | | | V |
| Collector-emitter breakdown voltage | $V_{(BR)CEO}$ | $I_C = -1\text{mA}, I_B = 0$ | -25 | | | V |
| Emitter-base breakdown voltage | $V_{(BR)EBO}$ | $I_E = -100\mu\text{A}, I_C = 0$ | -5 | | | V |
| Collector cut-off current | I_{CBO} | $V_{CB} = -40\text{V}, I_E = 0$ | | | -0.1 | μA |
| Collector cut-off current | I_{CEO} | $V_{CE} = -20\text{V}, I_B = 0$ | | | -0.1 | μA |
| Emitter cut-off current | I_{EBO} | $V_{EB} = -5\text{V}, I_C = 0$ | | | -0.1 | μA |
| DC current gain | h_{FE} | $V_{CE} = -1\text{V}, I_C = -50\text{mA}$ | 120 | | 400 | |
| Collector-emitter saturation voltage | $V_{CE(sat)}$ | $I_C = -500\text{mA}, I_B = -50\text{mA}$ | | | -0.6 | V |
| Base-emitter saturation voltage | $V_{BE(sat)}$ | $I_C = -500\text{mA}, I_B = -50\text{mA}$ | | | -1.2 | V |
| Transition frequency | f_T | $V_{CE} = -6\text{V}, I_C = -20\text{mA}, f = 30\text{MHz}$ | 150 | | | MHz |
| Collector output capacitance | C_{ob} | $V_{CB} = -10\text{V}, I_E = 0, f = 1\text{MHz}$ | | | 5 | pF |

CLASSIFICATION OF h_{FE}

| Rank | L | H | J |
|-------|---------|---------|---------|
| Range | 120-200 | 200-350 | 300-400 |

Typical Characteristics

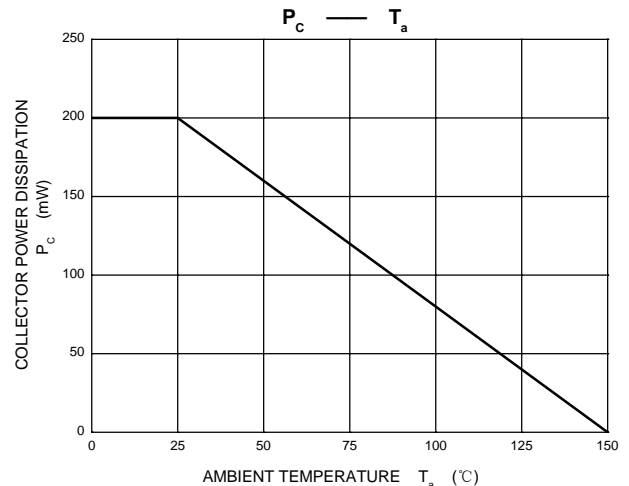
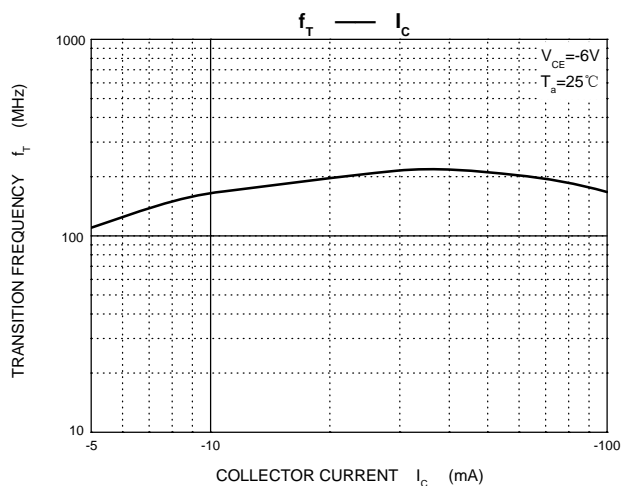
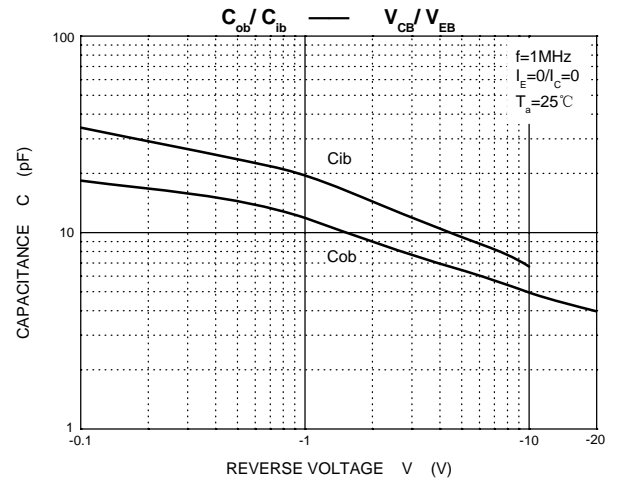
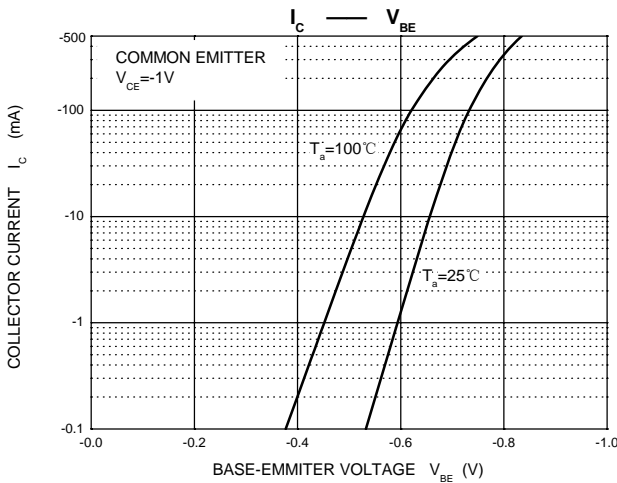
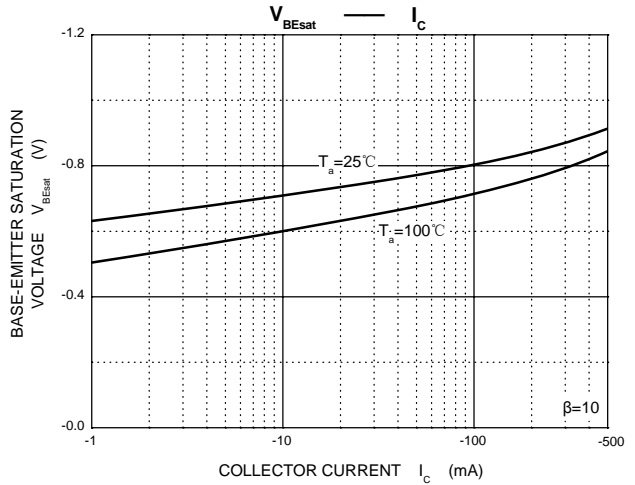
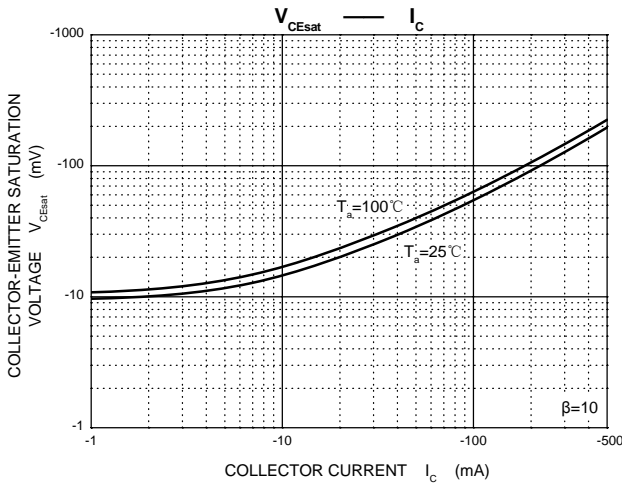
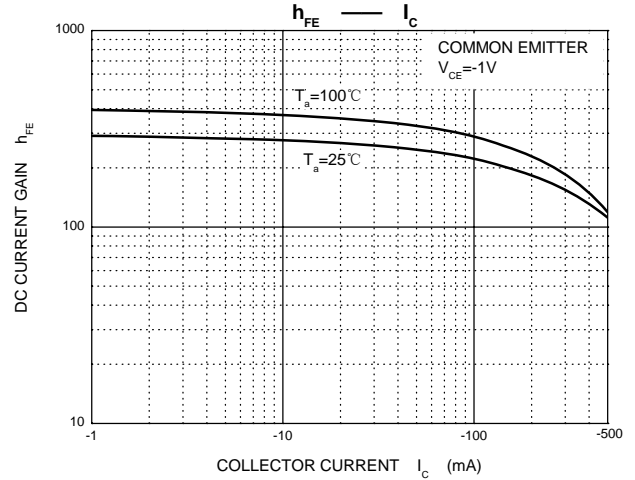
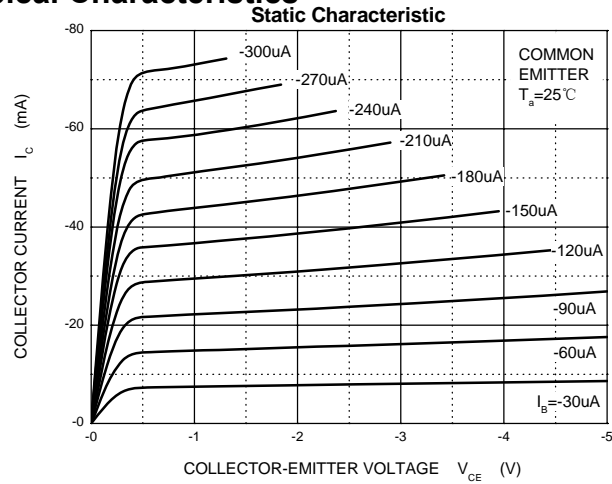

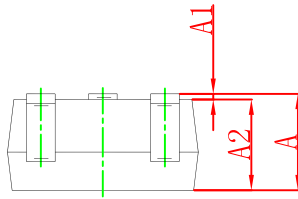
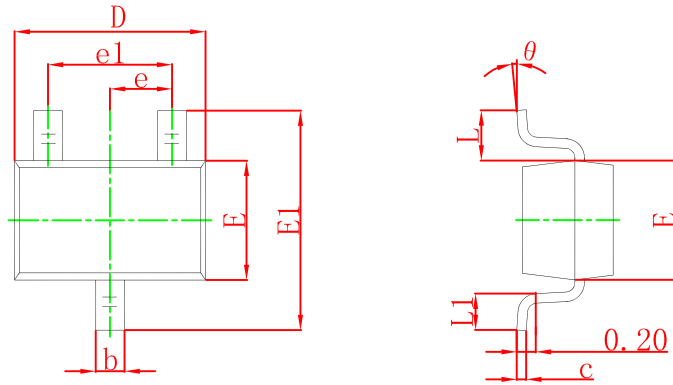

| Symbol | Dimensions In Millimeters | | Dimensions In Inches | |
|--------|---------------------------|-------|----------------------|-------|
| | Min | Max | Min | Max |
| A | 0.900 | 1.100 | 0.035 | 0.043 |
| A1 | 0.000 | 0.100 | 0.000 | 0.004 |
| A2 | 0.900 | 1.000 | 0.035 | 0.039 |
| b | 0.200 | 0.400 | 0.008 | 0.016 |
| c | 0.080 | 0.150 | 0.003 | 0.006 |
| D | 2.000 | 2.200 | 0.079 | 0.087 |
| E | 1.150 | 1.350 | 0.045 | 0.053 |
| E1 | 2.150 | 2.450 | 0.085 | 0.096 |
| e | 0.650 TYP | | 0.026 TYP | |
| e1 | 1.200 | 1.400 | 0.047 | 0.055 |
| L | 0.525 REF | | 0.021 REF | |
| L1 | 0.260 | 0.460 | 0.010 | 0.018 |
| θ | 0° | 8° | 0° | 8° |

SOT-323 Suggested Pad Layout

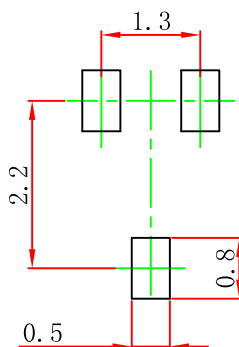

- Note:
1. Controlling dimension: in millimeters.
 2. General tolerance: ± 0.05 mm.
 3. The pad layout is for reference purposes only.