

SOT-323 Plastic-Encapsulate Transistors

FEATURES

- Complementary to MMST5401
- Small Surface Mount Package
- Ideal for Medium Power Amplification and Switching

MARKING:K4N

MAXIMUM RATINGS (T_a=25°C unless otherwise noted)

Symbol	Parameter	Value	Unit
V _{CB0}	Collector-Base Voltage	180	V
V _{CEO}	Collector-Emitter Voltage	160	V
V _{EBO}	Emitter-Base Voltage	6	V
I _C	Collector Current	600	mA
P _C	Collector Power Dissipation	200	mW
R _{θJA}	Thermal Resistance From Junction To Ambient	625	°C/W
T _J , T _{stg}	Operation Junction and Storage Temperature Range	-55~+150	°C

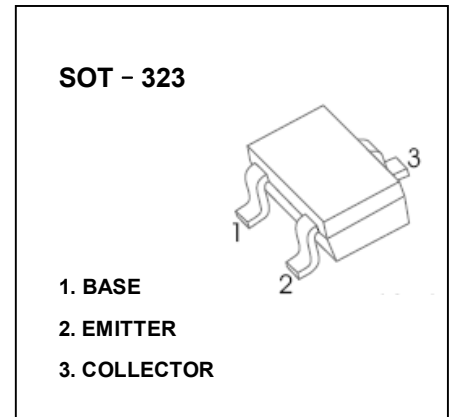

ELECTRICAL CHARACTERISTICS (T_a=25°C unless otherwise specified)

Parameter	Symbol	Test conditions	Min	Typ	Max	Unit
Collector-base breakdown voltage	V _{(BR)CBO}	I _C =100μA, I _E =0	180			V
Collector-emitter breakdown voltage	V _{(BR)CEO} *	I _C =1mA, I _B =0	160			V
Emitter-base breakdown voltage	V _{(BR)EBO}	I _E =10μA, I _C =0	6			V
Collector cut-off current	I _{CBO}	V _{CB} =120V, I _E =0			50	nA
Emitter cut-off current	I _{EBO}	V _{EB} =4V, I _C =0			50	nA
DC current gain	h _{FE}	V _{CE} =5V, I _C =1mA	80			
		V _{CE} =5V, I _C =10mA	100		300	
		V _{CE} =5V, I _C =50mA	30			
Collector-emitter saturation voltage	V _{CE(sat)}	I _C =50mA, I _B =5mA			0.2	V
		I _C =10mA, I _B =1mA			0.15	V
Base-emitter saturation voltage	V _{BE(sat)}	I _C =50mA, I _B =5mA			1	V
		I _C =10mA, I _B =1mA			1	V
Transition frequency	f _T	V _{CE} =10V, I _C =10mA, f=100MHz	100		300	MHz
Collector output capacitance	C _{ob}	V _{CB} =10V, I _E =0, f=1MHz			6	pF

*Pulse test: pulse width ≤300μs, duty cycles ≤ 2.0%.

Typical Characteristics

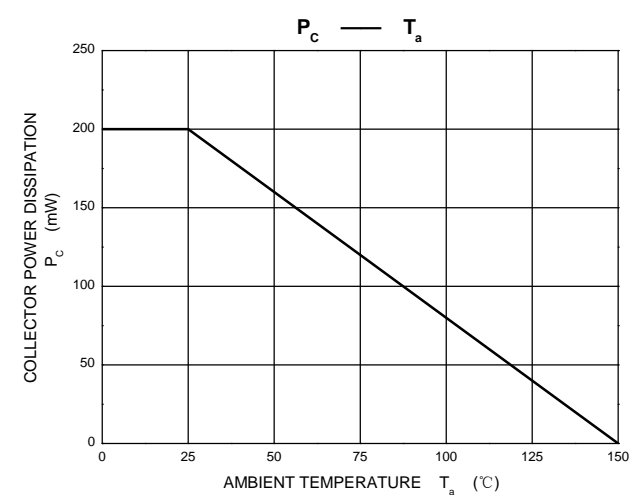
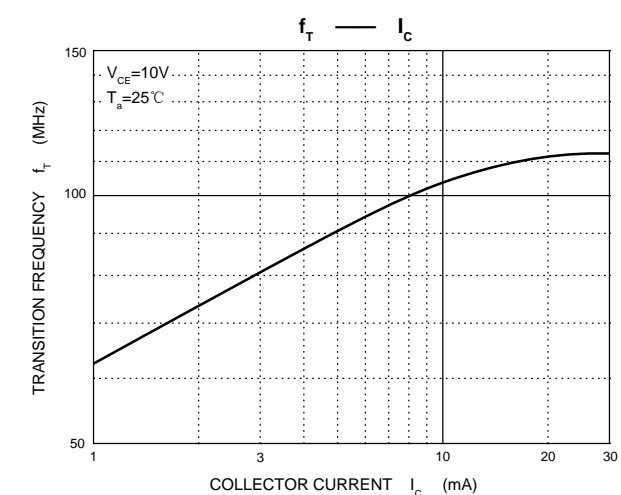
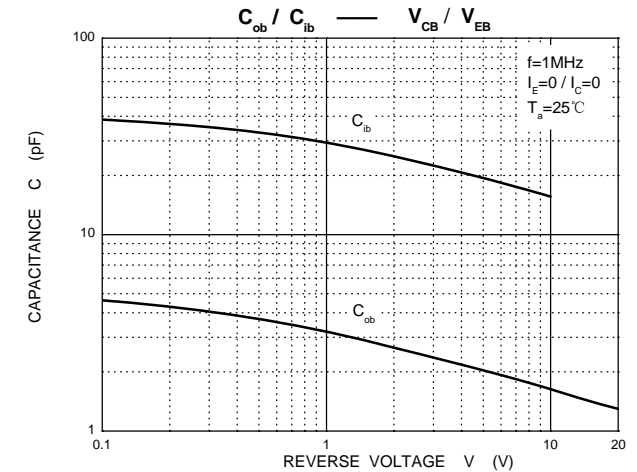
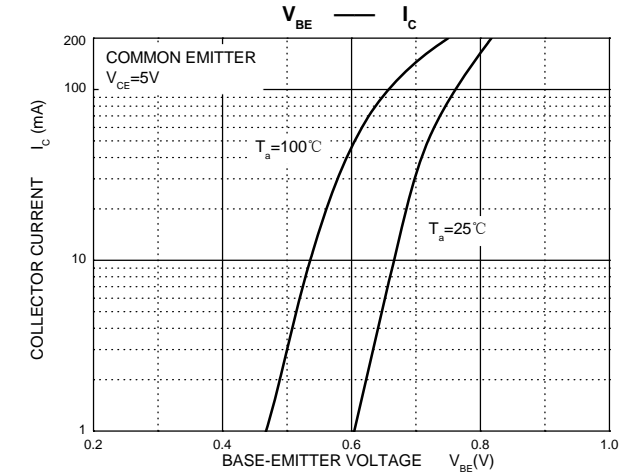
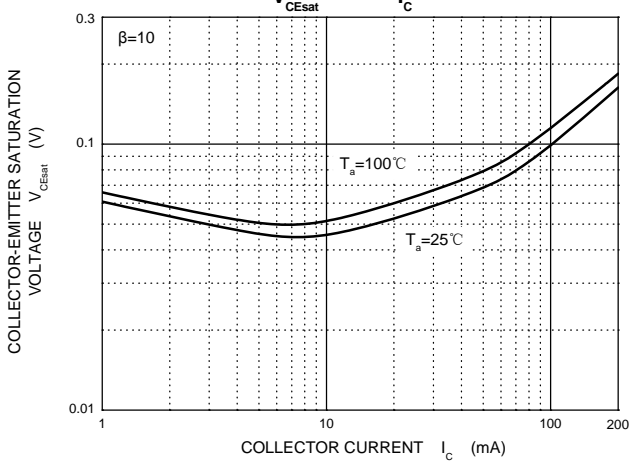
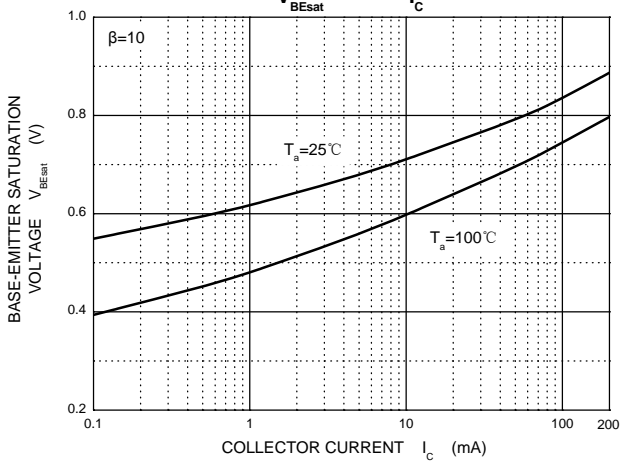
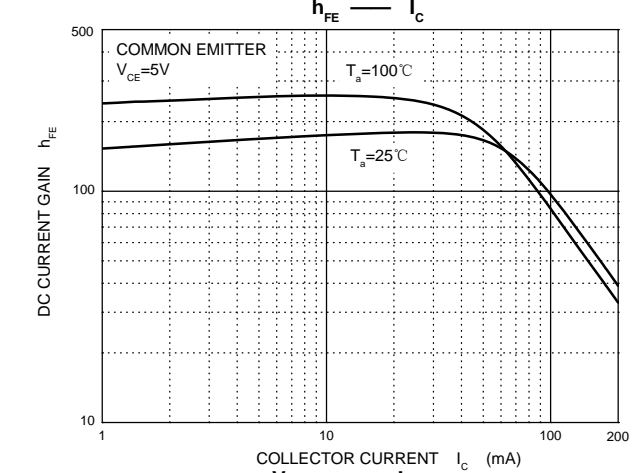
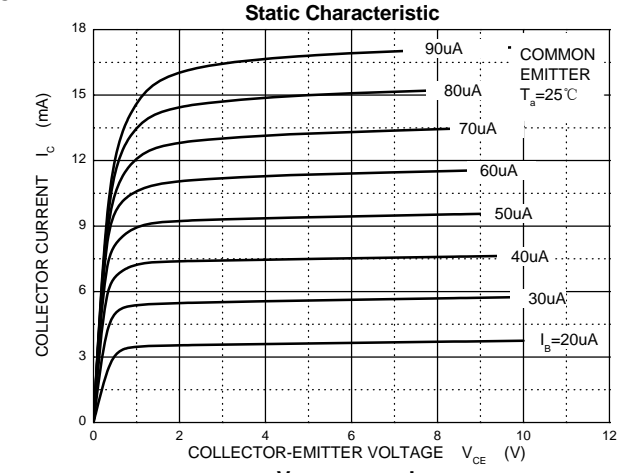

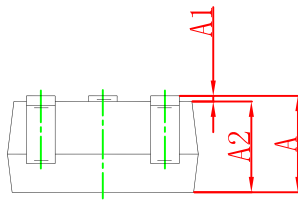
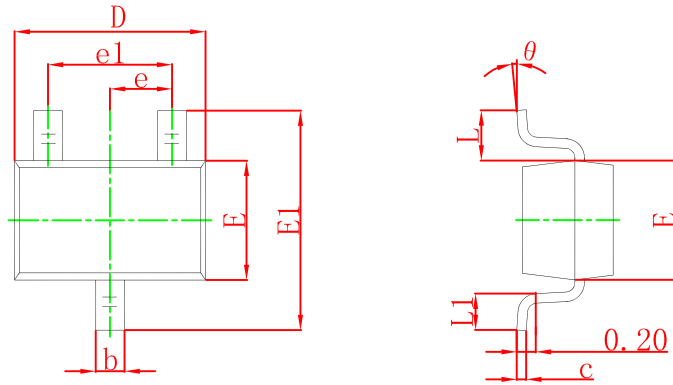

Symbol	Dimensions In Millimeters		Dimensions In Inches	
	Min	Max	Min	Max
A	0.900	1.100	0.035	0.043
A1	0.000	0.100	0.000	0.004
A2	0.900	1.000	0.035	0.039
b	0.200	0.400	0.008	0.016
c	0.080	0.150	0.003	0.006
D	2.000	2.200	0.079	0.087
E	1.150	1.350	0.045	0.053
E1	2.150	2.450	0.085	0.096
e	0.650 TYP		0.026 TYP	
e1	1.200	1.400	0.047	0.055
L	0.525 REF		0.021 REF	
L1	0.260	0.460	0.010	0.018
theta	0°	8°	0°	8°

SOT-323 Suggested Pad Layout

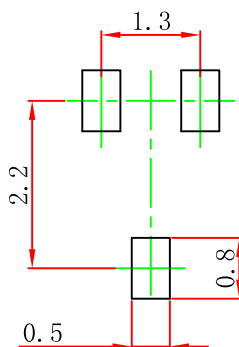

Note:

1. Controlling dimension: in millimeters.
2. General tolerance: ± 0.05 mm.
3. The pad layout is for reference purposes only.