

SOT-323 Plastic-Encapsulate Transistors

FEATURES

- Complementary to MMST4403
- Small Surface Mount Package

MARKING: K3X

MAXIMUM RATINGS ($T_a=25^\circ\text{C}$ unless otherwise noted)

Symbol	Parameter	Value	Unit
V_{CBO}	Collector-Base Voltage	60	V
V_{CEO}	Collector-Emitter Voltage	40	V
V_{EBO}	Emitter-Base Voltage	6	V
I_C	Collector Current	600	mA
P_C	Collector Power Dissipation	200	mW
$R_{\theta JA}$	Thermal Resistance From Junction To Ambient	625	$^\circ\text{C}/\text{W}$
T_J, T_{stg}	Operation Junction and Storage Temperature Range	-55~+150	$^\circ\text{C}$

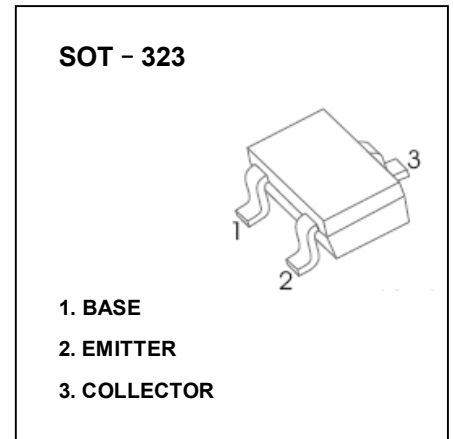

ELECTRICAL CHARACTERISTICS ($T_a=25^\circ\text{C}$ unless otherwise specified)

Parameter	Symbol	Test conditions	Min	Typ	Max	Unit
Collector-base breakdown voltage	$V_{(BR)CBO}$	$I_C=100\mu\text{A}, I_E=0$	60			V
Collector-emitter breakdown voltage	$V_{(BR)CEO}$	$I_C=1\text{mA}, I_B=0$	40			V
Emitter-base breakdown voltage	$V_{(BR)EBO}$	$I_E=100\mu\text{A}, I_C=0$	6			V
Collector cut-off current	I_{CBO}	$V_{CB}=35\text{V}, I_E=0$			100	nA
Collector cut-off current	I_{CEO}	$V_{CE}=35\text{V}, I_B=0$			500	nA
DC current gain	h_{FE}	$V_{CE}=1\text{V}, I_C=100\mu\text{A}$	20			
		$V_{CE}=1\text{V}, I_C=1\text{mA}$	40			
		$V_{CE}=1\text{V}, I_C=10\text{mA}$	80			
		$V_{CE}=1\text{V}, I_C=150\text{mA}$	100		300	
		$V_{CE}=2\text{V}, I_C=500\text{mA}$	40			
Collector-emitter saturation voltage	$V_{CE(sat)}$	$I_C=150\text{mA}, I_B=15\text{mA}$			0.4	V
		$I_C=500\text{mA}, I_B=50\text{mA}$			0.75	V
Base-emitter saturation voltage	$V_{BE(sat)}$	$I_C=150\text{mA}, I_B=15\text{mA}$	0.75		0.95	V
		$I_C=500\text{mA}, I_B=50\text{mA}$			1.2	V
Transition frequency	f_T	$V_{CE}=10\text{V}, I_C=20\text{mA}, f=100\text{MHz}$	250			MHz
Collector output capacitance	C_{ob}	$V_{CB}=5\text{V}, I_E=0, f=1\text{MHz}$			6.5	pF

Typical Characteristics

Static Characteristic

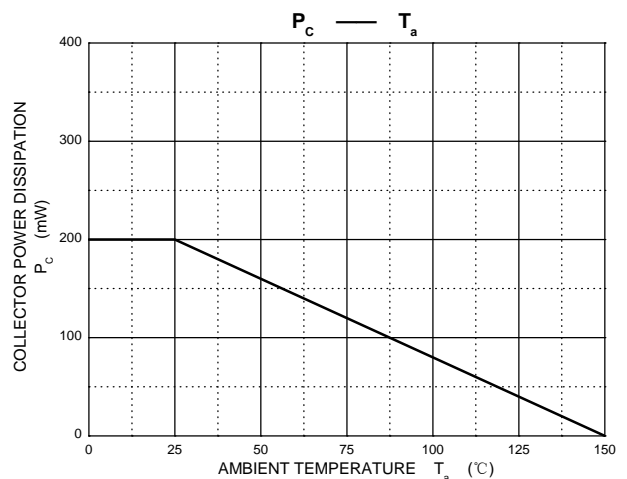
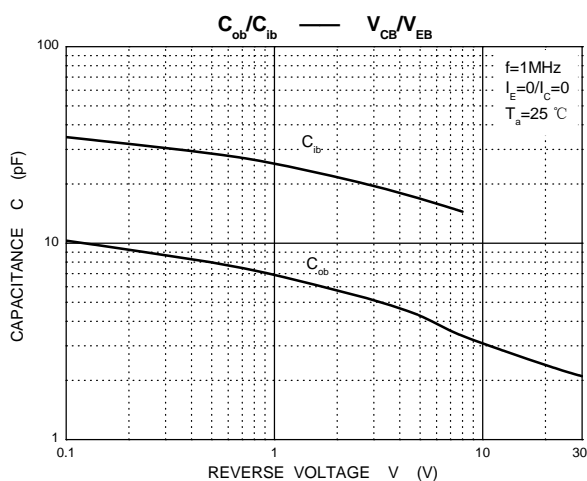
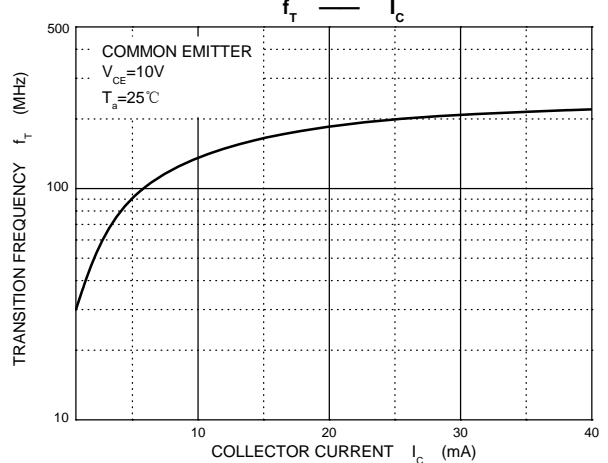
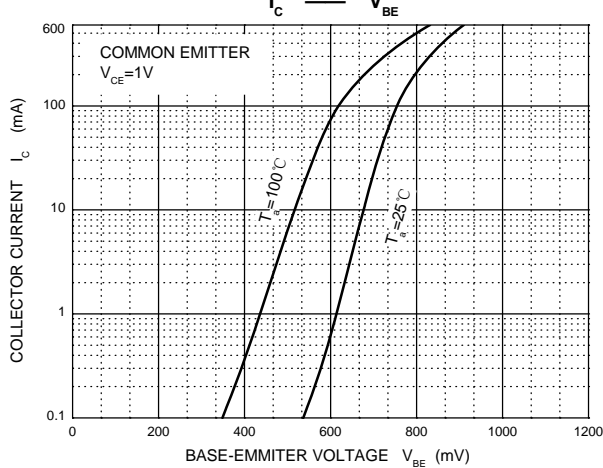
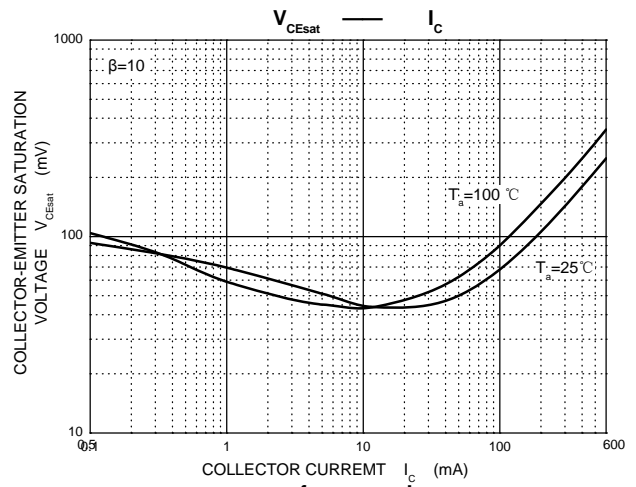
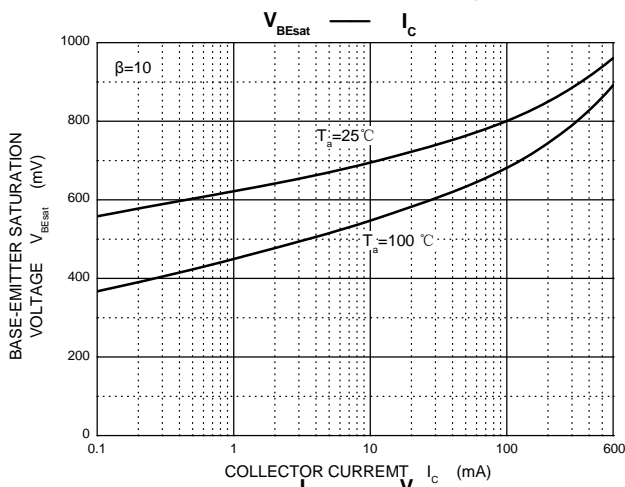
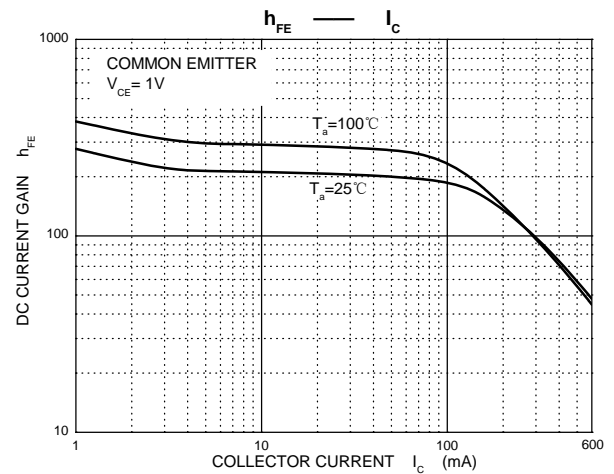
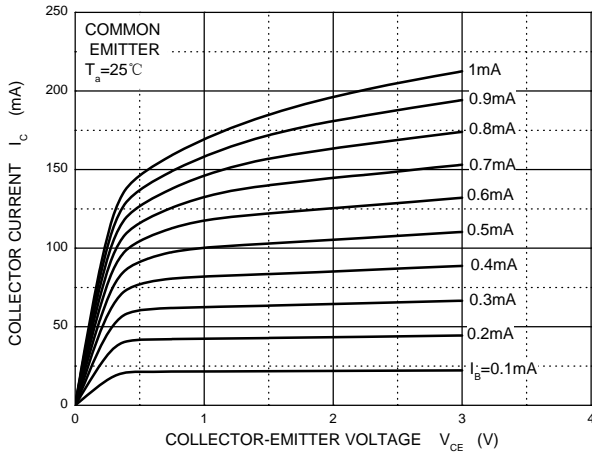

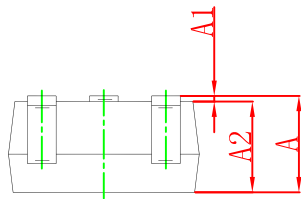
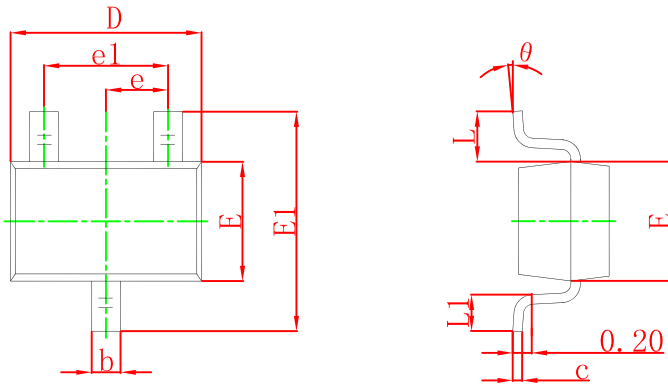

Symbol	Dimensions In Millimeters		Dimensions In Inches	
	Min	Max	Min	Max
A	0.900	1.100	0.035	0.043
A1	0.000	0.100	0.000	0.004
A2	0.900	1.000	0.035	0.039
b	0.200	0.400	0.008	0.016
c	0.080	0.150	0.003	0.006
D	2.000	2.200	0.079	0.087
E	1.150	1.350	0.045	0.053
E1	2.150	2.450	0.085	0.096
e	0.650 TYP		0.026 TYP	
e1	1.200	1.400	0.047	0.055
L	0.525 REF		0.021 REF	
L1	0.260	0.460	0.010	0.018
θ	0°	8°	0°	8°

SOT-323 Suggested Pad Layout

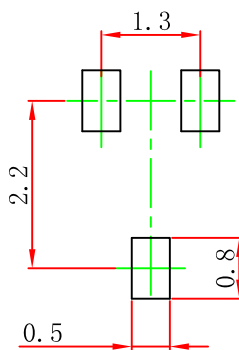

- Note:
1. Controlling dimension: in millimeters.
 2. General tolerance: ± 0.05 mm.
 3. The pad layout is for reference purposes only.