

PNP Silicon Epitaxial Planar Transistor
for switching and amplifier applications

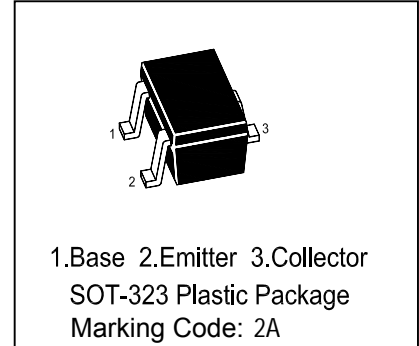

MAXIMUM RATINGS ($T_A=25^{\circ}\text{C}$ unless otherwise noted)

Parameter	Symbol	Value	Unit
Collector Base Voltage	$-V_{CBO}$	40	V
Collector Emitter Voltage	$-V_{CEO}$	40	V
Emitter Base Voltage	$-V_{EBO}$	5	V
Collector Current	$-I_C$	200	mA
Total Power Dissipation	P_{tot}	200	mW
Junction Temperature	T_j	150	$^{\circ}\text{C}$
Storage Temperature Range	T_{stg}	- 55 to +150	$^{\circ}\text{C}$

Characteristics at $T_a = 25\text{ }^\circ\text{C}$

Parameter	Symbol	Min.	Max.	Unit
DC Current Gain at $-V_{CE} = 1\text{ V}$, $-I_C = 0.1\text{ mA}$	h_{FE}	60	-	-
at $-V_{CE} = 1\text{ V}$, $-I_C = 1\text{ mA}$	h_{FE}	80	-	-
at $-V_{CE} = 1\text{ V}$, $-I_C = 10\text{ mA}$	h_{FE}	100	300	-
at $-V_{CE} = 1\text{ V}$, $-I_C = 50\text{ mA}$	h_{FE}	60	-	-
at $-V_{CE} = 1\text{ V}$, $-I_C = 100\text{ mA}$	h_{FE}	30	-	-
Collector Emitter Cutoff Current at $-V_{CE} = 30\text{ V}$	$-I_{CES}$	-	50	nA
Emitter Base Cutoff Current at $-V_{EB} = 3\text{ V}$	$-I_{EBO}$	-	50	nA
Collector Base Breakdown Voltage at $-I_C = 10\text{ }\mu\text{A}$	$-V_{(BR)CBO}$	40	-	V
Collector Emitter Breakdown Voltage at $-I_C = 1\text{ mA}$	$-V_{(BR)CEO}$	40	-	V
Emitter Base Breakdown Voltage at $-I_E = 10\text{ }\mu\text{A}$	$-V_{(BR)EBO}$	5	-	V
Collector Emitter Saturation Voltage at $-I_C = 10\text{ mA}$, $-I_B = 1\text{ mA}$	$-V_{CE(sat)}$	-	0.25	V
at $-I_C = 50\text{ mA}$, $-I_B = 5\text{ mA}$		-	0.4	
Base Emitter Saturation Voltage at $-I_C = 10\text{ mA}$, $-I_B = 1\text{ mA}$	$-V_{BE(sat)}$	0.65	0.85	V
at $-I_C = 50\text{ mA}$, $-I_B = 5\text{ mA}$		-	0.95	
Transition Frequency at $-V_{CE} = 20\text{ V}$, $I_E = 10\text{ mA}$, $f = 100\text{ MHz}$	f_T	250	-	MHz
Collector Output Capacitance at $-V_{CB} = 10\text{ V}$, $f = 100\text{ KHz}$	C_{ob}	-	4.5	pF
Delay Time at $-V_{CC} = 3\text{ V}$, $-V_{BE(OFF)} = 0.5\text{ V}$, $-I_C = 10\text{ mA}$, $-I_{B1} = 1\text{ mA}$	t_d	-	35	ns
Rise Time at $-V_{CC} = 3\text{ V}$, $-V_{BE(OFF)} = 0.5\text{ V}$, $-I_C = 10\text{ mA}$, $-I_{B1} = 1\text{ mA}$	t_r	-	35	ns
Storage Time at $-V_{CC} = 3\text{ V}$, $-I_C = 10\text{ mA}$, $I_{B1} = -I_{B2} = -1\text{ mA}$	t_{stg}	-	225	ns
Fall Time at $-V_{CC} = 3\text{ V}$, $-I_C = 10\text{ mA}$, $I_{B1} = -I_{B2} = -1\text{ mA}$	t_f	-	75	ns

Typical Characteristics

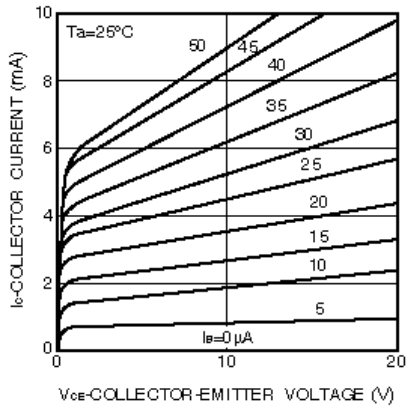

Fig.1 Grounded emitter output characteristics

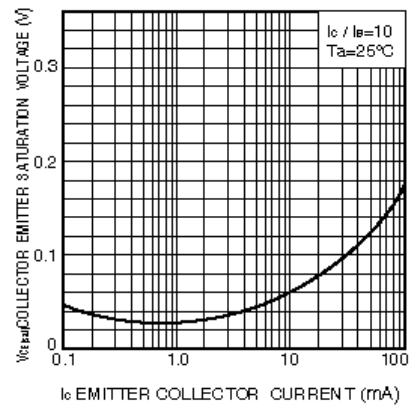

Fig.2 Collector-emitter saturation voltage vs. collector current

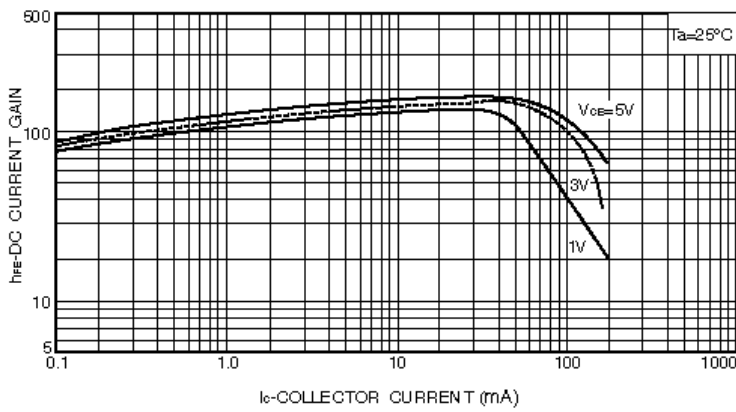

Fig.3 DC current gain vs. collector current (I)

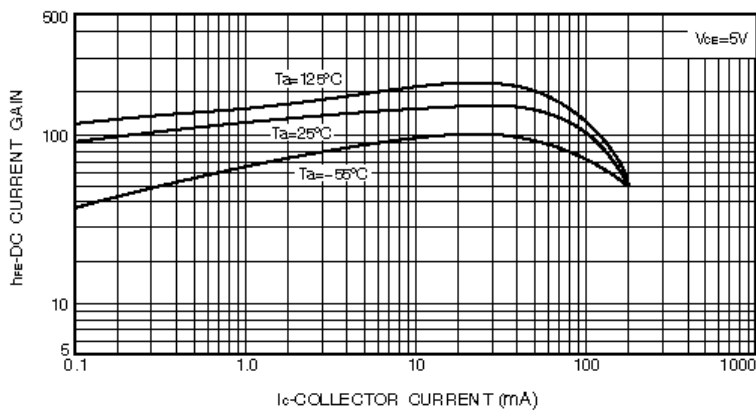

Fig.4 DC current gain vs. collector current (II)

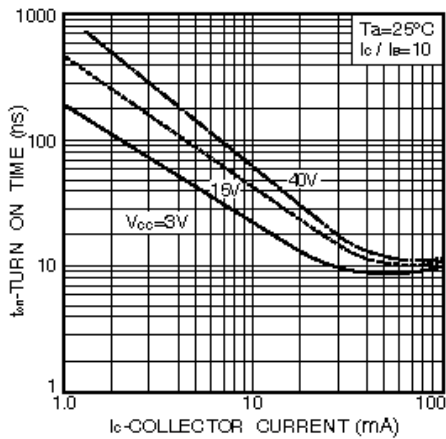

Fig. 8 Turn-on time vs. collector current

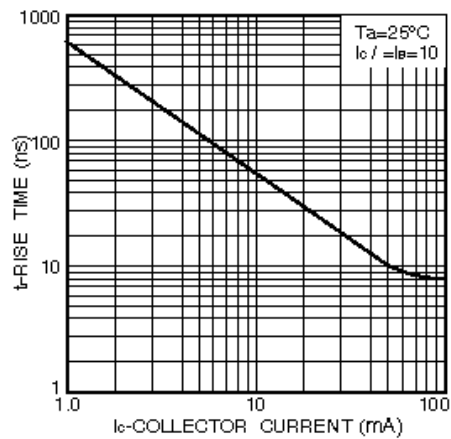

Fig. 9 Rise time vs. collector current

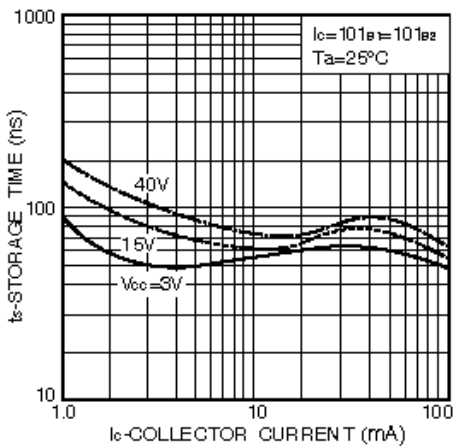

Fig. 10 Storage time vs. collector current

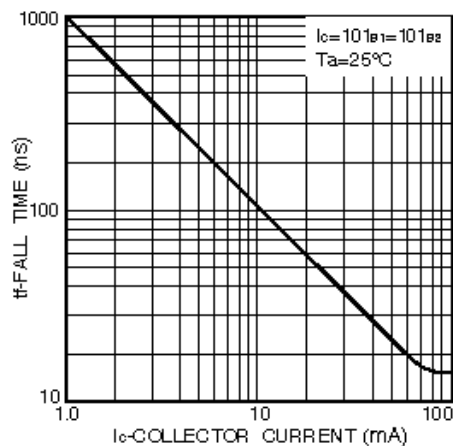

Fig. 11 Fall time vs. collector current

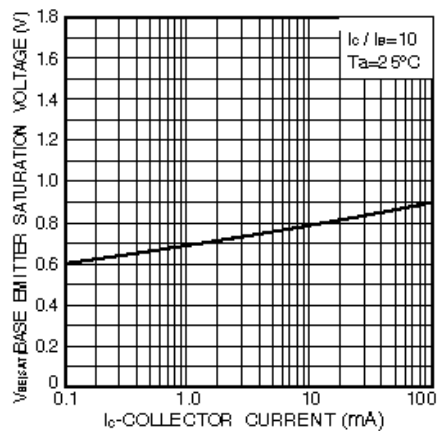

Fig. 6 Base-emitter saturation voltage vs. collector current

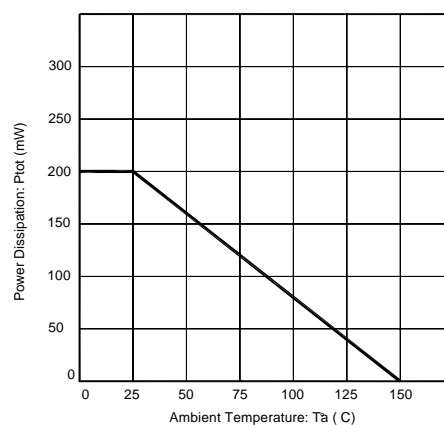
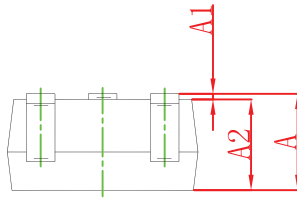
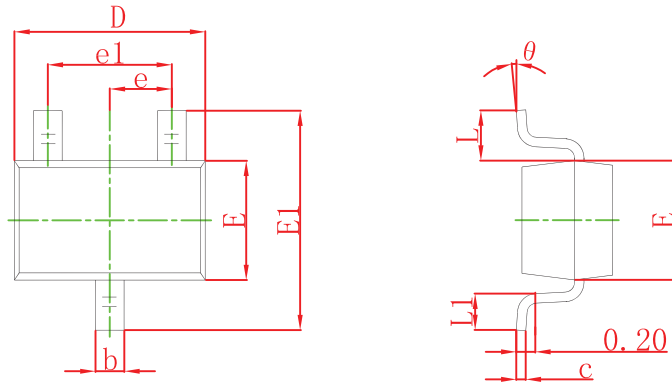
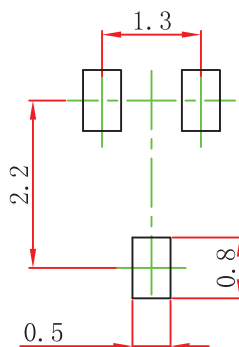

Fig. 10 Power Dissipation vs. Ambient Temperature



Symbol	Dimensions In Millimeters		Dimensions In Inches	
	Min	Max	Min	Max
A	0.900	1.100	0.035	0.043
A1	0.000	0.100	0.000	0.004
A2	0.900	1.000	0.035	0.039
b	0.200	0.400	0.008	0.016
c	0.080	0.150	0.003	0.006
D	2.000	2.200	0.079	0.087
E	1.150	1.350	0.045	0.053
E1	2.150	2.450	0.085	0.096
e	0.650 TYP		0.026 TYP	
e1	1.200	1.400	0.047	0.055
L	0.525 REF		0.021 REF	
L1	0.260	0.460	0.010	0.018
theta	0°	8°	0°	8°

SOT-323 Suggested Pad Layout



- Note:
1. Controlling dimension: in millimeters.
 2. General tolerance: ± 0.05 mm.
 3. The pad layout is for reference purposes only.