

FEATURES

- ✧ Small body outline dimensions:
0.063" × 0.032" (1.6×0.8 mm)
- ✧ Protects one bi-directional I/O line
- ✧ Low clamping voltage
- ✧ Working voltage: 12V
- ✧ Low leakage current
- ✧ RoHS compliant

MAIN APPLICATIONS

- ✧ LED light bar
- ✧ Cell phone handsets and accessories
- ✧ Microprocessor based equipment
- ✧ Personal digital assistants (PDA's)
- ✧ Notebooks, desktops, and servers
- ✧ Portable instrumentation
- ✧ Peripherals
- ✧ Digital cameras

PROTECTION SOLUTION TO MEET

- ✧ IEC61000-4-2 (ESD) ±20kV (air), ±20kV (contact)
- ✧ IEC61000-4-4 (EFT) 40A (5/50ns)
- ✧ IEC61000-4-5 (Lightning) 5A (8/20µs)

MECHANICAL CHARACTERISTICS

- ✧ SOD-523 package
- ✧ Molding compound flammability rating: UL 94V-0
- ✧ Weight 0.5 milligrams (approximate)
- ✧ Quantity per reel: 5,000pcs
- ✧ Lead finish: lead free

MARKING CODE

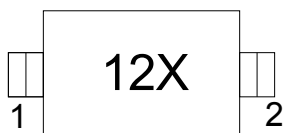

ORDERING INFORMATION

PART No.	PACKAGE TYPE	QUANTITY(PCS) REEL	DESCRIPTION
TESDB12D5	SOD-523	5,000	7 inch reel pack

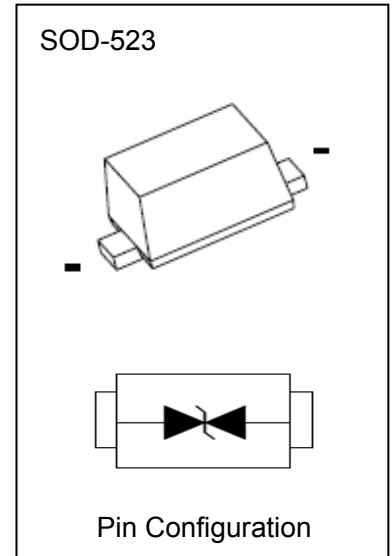

ABSOLUTE MAXIMUM RATINGS ($T_A=25^{\circ}\text{C}$, RH=45%-75%, unless otherwise noted)

Parameter	Symbol	Value	Unit
Peak pulse power dissipation on 8/20 μs waveform	P_{PP}	100	W
ESD per IEC 61000-4-2 (Air) ESD per IEC 61000-4-2 (Contact)	V_{ESD}	+/- 20 +/- 20	kV
Lead soldering temperature	T_L	260 (10 sec.)	$^{\circ}\text{C}$
Operating junction temperature range	T_J	-55 to +125	$^{\circ}\text{C}$
Storage temperature range	T_{STG}	-55 to +150	$^{\circ}\text{C}$

ELECTRICAL CHARACTERISTICS ($T_A=25^{\circ}\text{C}$)

Parameter	Symbol	Conditions	Min	Typ	Max	Unit
Reverse working voltage	V_{RWM}				12	V
Reverse breakdown voltage	V_{BR}	$I_T=1\text{mA}$	13.3			V
Reverse leakage current	I_R	$V_{RWM}=12\text{V}$			0.1	μA
Clamping voltage	V_C	$I_{PP}=5\text{A}$, $t_P=8/20\mu\text{s}$		22	26	V
Junction capacitance	C_J	$V_{RWM}=0\text{V}$, $f=1\text{MHz}$		10	20	pF

RATINGS AND V-I CHARACTERISTICS CURVES ($T_A=25^\circ\text{C}$, unless otherwise noted)

FIG.1: V- I curve characteristics (Bi-directional)

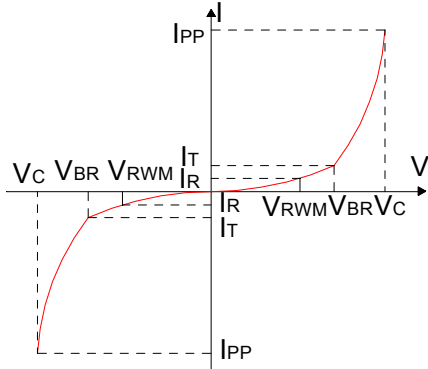

FIG.2: Pulse waveform (8/20 μs)

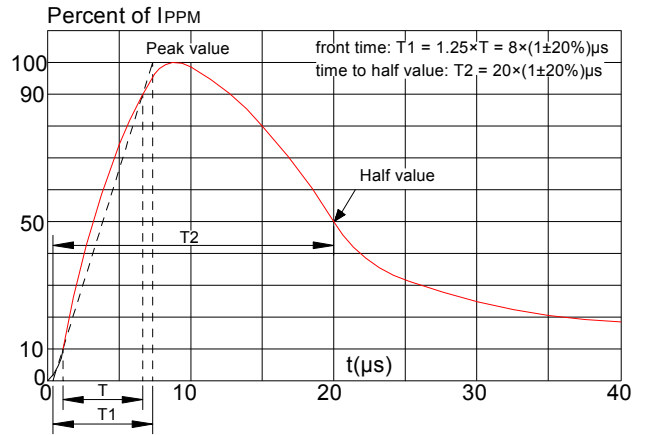

FIG.3: Pulse derating curve

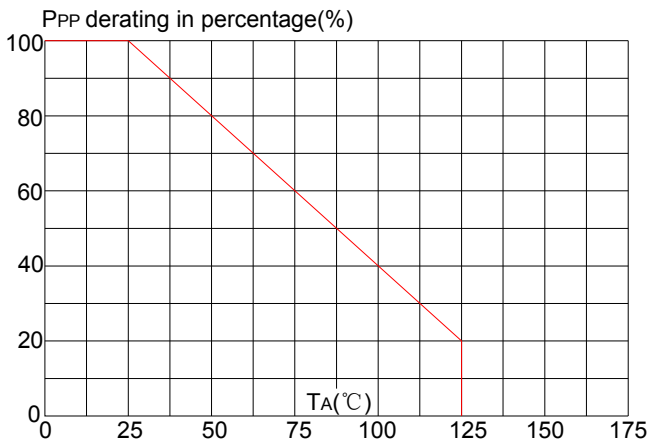
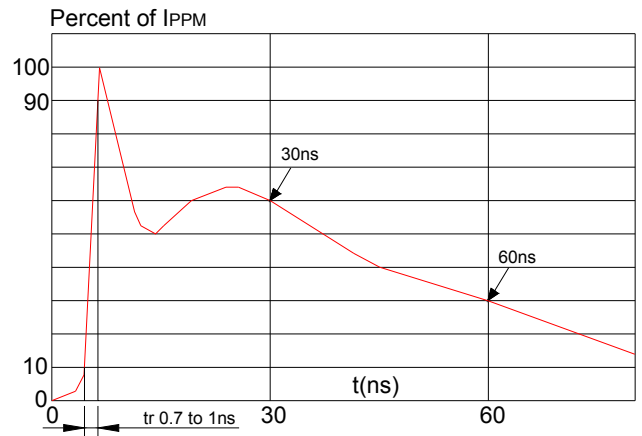
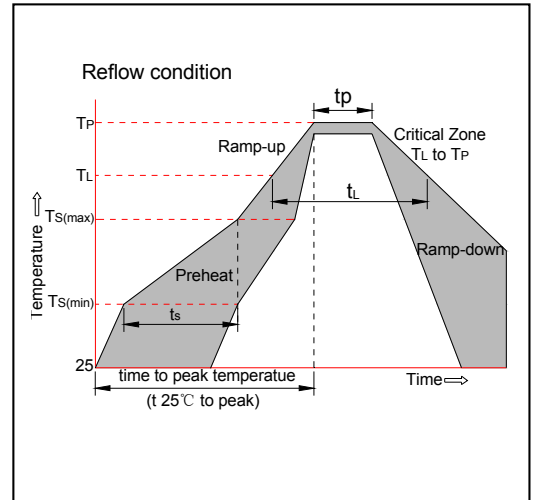

FIG.4: ESD clamping (20kV contact)



SOLDERING PARAMETERS

Reflow Condition		Pb-Free assembly (see figure at right)
Pre Heat	-Temperature Min ($T_{s(min)}$)	+150°C
	-Temperature Max($T_{s(max)}$)	+200°C
	-Time (Min to Max) (t_s)	60-180 secs.
Average ramp up rate (Liquidus Temp (T_L) to peak)		3°C/sec. Max
$T_{s(max)}$ to T_L - Ramp-up Rate		3°C/sec. Max
Reflow	-Temperature(T_L)(Liquidus)	+217°C
	-Temperature(t_L)	60-150 secs.
Peak Temp (T_p)		+260(+0/-5)°C
Time within 5°C of actual Peak Temp (t_p)		20-40secs.
Ramp-down Rate		6°C/sec. Max
Time 25°C to Peak Temp (T_p)		8 min. Max
Do not exceed		+260°C



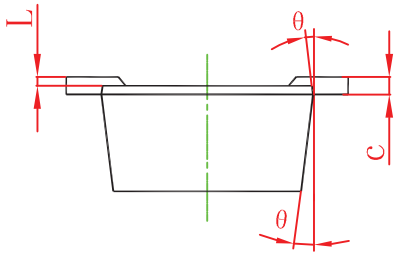
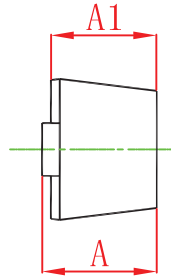
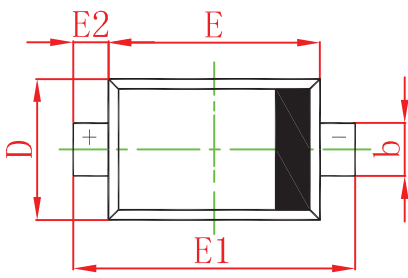

Symbol	Dimensions In Millimeters		Dimensions In Inches	
	Min	Max	Min	Max
A	0.510	0.770	0.020	0.031
A1	0.400	0.700	0.015	0.028
b	0.250	0.350	0.010	0.014
c	0.080	0.150	0.003	0.006
D	0.750	0.850	0.030	0.033
E	1.100	1.300	0.043	0.051
E1	1.500	1.700	0.059	0.067
E2	0.200 REF		0.008 REF	
L	0.010	0.070	0.001	0.003
θ	7° REF		7° REF	

SOD-523 Suggested Pad Layout

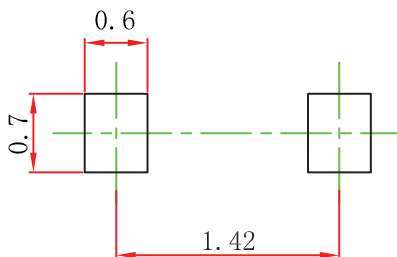

Note:

1. Controlling dimension: in millimeters.
2. General tolerance: $\pm 0.05\text{mm}$.
3. The pad layout is for reference purposes only.